

FLUSH ROOF MOUNTING INSTALLATION GUIDE

November 2014

BEFORE YOU BEGIN

- » Consult the Authority Having Jurisdiction (AHJ) for wind, snow, and seismic design loads, as well as other considerations.
- » Ensure that the installation is performed by a licensed solar PV installation professional.
- » Verify that roof is sound and capable of supporting the additional load of the PV array within local climatic conditions. Look for signs of weak or low laying roof surfaces and inner structure which may need repair or leveling.
- » Consult Sunfix plus span charts for allowable rail spans and cantilever lengths.
- » Comply with the solar panel's installation manual for approved attachment locations and methods.
- » Comply with all local, state, and federal codes.
- » Comply with all roofing manufacturer's warranties.
- » Use only Sunfix plus parts supplied by SolarWorld.
- » The information within this guide is subject to change without notice.

TOOLS NEEDED

- » 13 mm socket
- » 7/16 inch socket
- » Torx T40 drive bit
- » Torque wrench (0-30 ft-lb)
- » Safety equipment
- » Chalk line

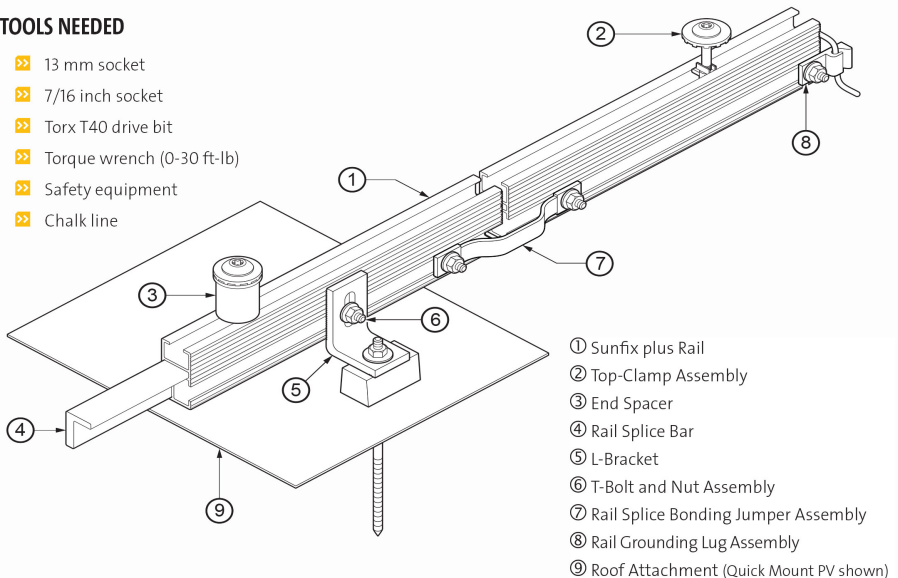

1. INSTALL ROOF ATTACHMENTS AND L-BRACKET

- 1.1. Snap a chalk line to ensure attachments and rail will be in line and square to roof.

TIP: To ensure the array is square to the roof, snap a second line perpendicular to the line snapped in Step 1.1.

- 1.2. Install roof attachments and flashings per manufacturer's instruction manual.
- 1.3. Pre-assemble T-Bolt and Nut Assembly ② on the long side of the L-Bracket ③ with the T-head on the outside as shown in **Figure 1.3**. Preassemble loosely, with anti-seize compound on threads.
- 1.4. Attach short side of pre-assembled L-Bracket to Roof Attachment ④ per attachment instruction manual. Quick Mount PV shown in **Figure 1.4**.

2. INSTALL RAILS

- 2.1. Insert T-head of bolt (now connected to L-bracket) into the channel on the long side of the Sunfix plus Rail ⑤, as shown in **Figure 2.1**.
- 2.2. Hand tighten nut. As tightening occurs, the T-head will lock perpendicular to the rail. Verify T-head is in this position, as shown in **Figure 2.2**.
- 2.3. Repeat Steps 2.1 and 2.2 for all attachments. Adjust and level rail up and down and side to side as necessary. Tighten nut to a torque of 12 ft-lbs.

3. INSTALL RAIL SPLICES AND RACKING BONDING/GROUNDING (AS REQUIRED)

- 3.1. To connect rail sections, Sunfix plus utilizes a loose fitting, fastener-free Rail Splice Bar ⑥ to allow for transfer of load and thermal expansion/contraction. To install, insert the Rail Splice Bar into the rails until the raised index touches the rail end, as shown in **Figure 3.1**.
- 3.2. For rail-to-rail electrical continuity (bonding), a Rail Splice Bonding Jumper Assembly ⑦ is used. To install, insert assembly's T-bolts into the channel on the long side of rail and secure, similar to Steps 2.1 and 2.2. Be sure to allow slack in jumper to allow for thermal expansion. Refer to **Figure 3.2**. Tighten to 12 ft-lbs using general purpose anti-seize compound.
- 3.3. At the end of each row attach the Rail Grounding Lug Assembly ⑧ similar to steps 2.1 and 2.2. Be sure to install Rail Grounding Lug Assembly parallel to rail, ensuring the teeth of the grounding WEEB firmly "bite" into rail. Torque rail-connecting bolt to 12 ft-lbs using general purpose anti-seize compound. After inserting grounding wire, torque ground-connecting bolt to 7 ft-lbs. Refer to **Figure 3.3**.

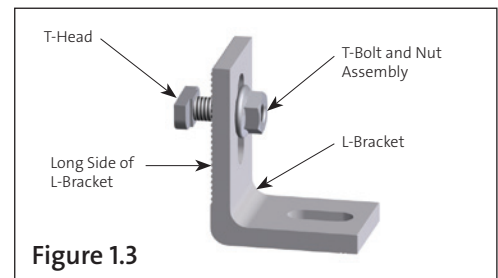

Figure 1.3

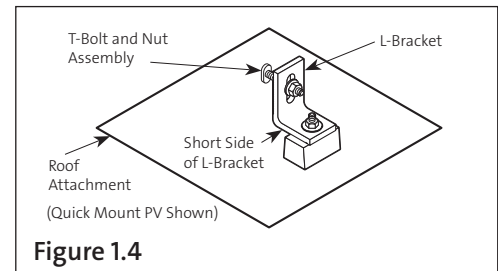

Figure 1.4

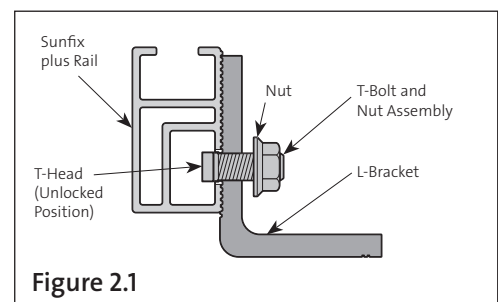

Figure 2.1

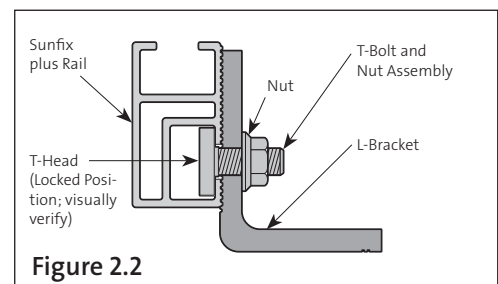

Figure 2.2

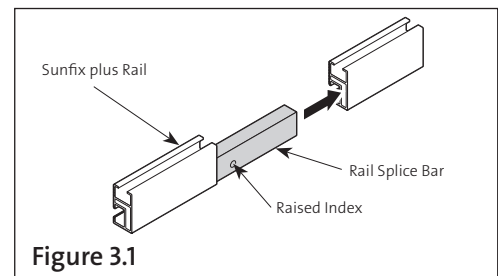

Figure 3.1

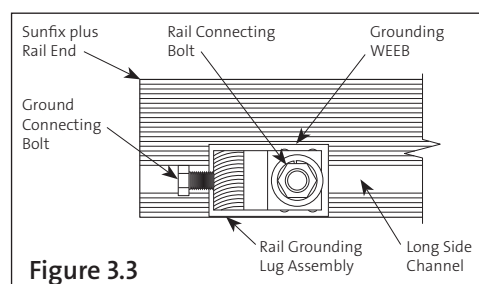

Figure 3.3

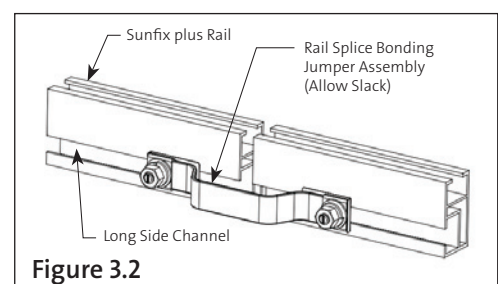

Figure 3.2

4. MODULE INSTALLATION

TIP: Consider wire management and solar panel grounding before installing solar panels. Wire management spaced at 12" along the rail is suggested. Wire management that is UV resistant, rated for climate, and has a 25-year service life is appropriate.

- 4.1. If top hat style WEEB DPF (part # EC0534) is to be used, pre-assemble into Top-Clamp Assembly ②, as shown in **Figure 4.1a**. Note that not every Top-Clamp Assembly needs a WEEB. Follow the WEEB layout diagrams in **Figure 4.1b**.
- 4.2. To install Top-clamp Assembly, hold Top-Clamp Assembly by the plastic taps above channel nut as shown in **Figure 4.2**.
- 4.3. Insert Top-Clamp Assembly into the rail's short side channel about $\frac{1}{2}$ " from the rail end. To lock, sit bottom of plastic guide against the bottom of the channel, and twist $\frac{1}{4}$ turn clockwise to lock Top-Clamp Assembly into the channel (plastic taps will be perpendicular to rail). Refer to **Figures 4.3** and **4.6**. Repeat Steps 4.2 and 4.3 for the second rail. (Each solar panel will be attached to two rails.)
- 4.4. From the end of the rail, measure the width of the solar panel, plus about 5". (These additional 5" will ensure that the Top-Clamp Assemblies do not interfere with module placement.) Repeat for second rail. Refer to **Figure 4.6**.
- 4.5. Measure and mark $1\frac{1}{4}$ " from the end of rail. Lay solar panel against rail (between the clamps). Align the edge of the solar panel with this $1\frac{1}{4}$ " mark. Verify the manufacturer's approved solar panel attachment locations are being met. Refer to **Figure 4.6**.
- 4.6. Keeping the solar panel still and the plastic tabs perpendicular to the rail, slide the four Top-Clamp Assemblies to the solar panel. Be sure the Top-Clamp Assembly's plastic tabs are flush with the edge of the solar panel. Refer to **Figure 4.6**.
- 4.7. At the row end, insert End Spacers ③ between the Top-Clamp Assembly's washer and Sunfix plus Rail, as shown in **Figure 4.7**. Tighten these outer Top-Clamp Assemblies to 15 ft-lbs using general purpose anti-seize compound, or if using WEEBs, tighten to manufacturers specifications (EC0534 WEEB DPF requires 12 ft-lbs).
- 4.8. Continue to lay solar panels in place, bringing them flush to the plastic tabs, and tightening the Top-Clamp Assemblies – similar to Step 4.7. (Revealing a $\frac{3}{8}$ " gap between solar panels.) Insert the End Spacer at the end of the row as in Step 4.7. Be sure solar panel edge is greater than 1" from rail end/splice, as shown in **Figure 4.8**.

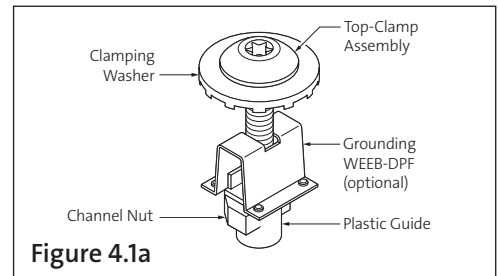

Figure 4.1a

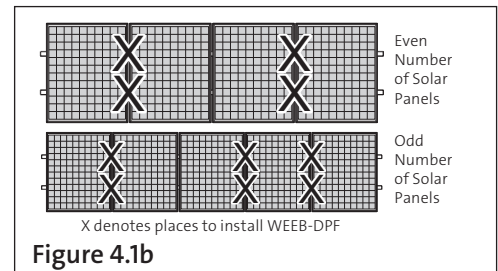

Figure 4.1b

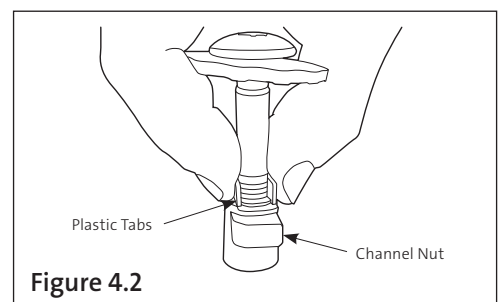

Figure 4.2

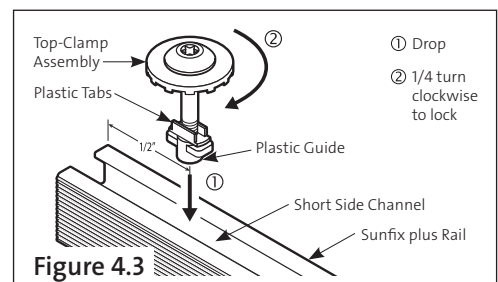

Figure 4.3

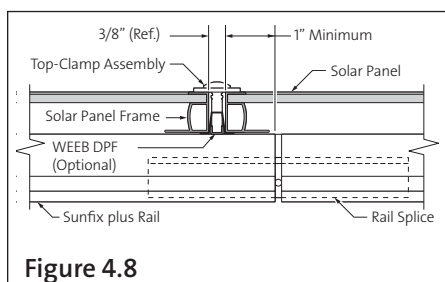

Figure 4.8

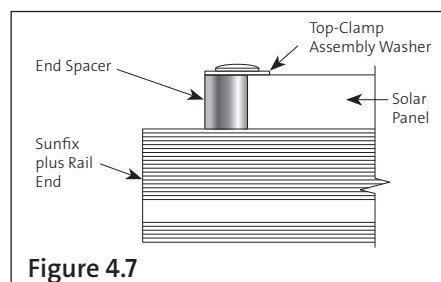

Figure 4.7

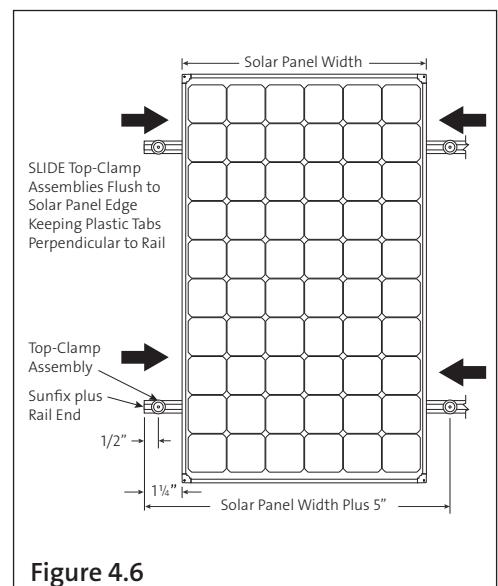

Figure 4.6

5. SUNSKIRT INSTALLATION GUIDE (OPTIONAL) – FOR FIRE CODE REQUIREMENTS

5.1. Portrait Installation (Refer to Figure 5.1)

5.1.1. Align the left edge of the module with the left edge of the Sunskirt. Place the Toothed Washer (EC1151) on the Thread-Cutting Screw (EC1200). Insert screw through Sunskirt's hole and into the corner key's hole. Tighten to 32 in-lbs. Refer to **Figure 5.1.1**. Repeat for all modules on the bottom edge of the array.

5.2. Landscape Installation (Refer to Figure 5.2)

5.2.1. Place the WEEB DPR (EC1204) on the T-head bolt (SH0001), with the WEEB's tabs pointing away from Bolt's T-head. Then insert Bolt through the Sunskirt's slot and thread on the Hex Nut (EC0496) until about three threads show beyond the Hex Nut. Refer to **Figures 5.2.1a & 5.2.1b**.

5.2.2. From the low end of the Sunfix plus rail, slide the assembly up so the Bolt's T-head is captured by the Sunfix plus rail's top channel (and WEEB rides along the top of the channel), as shown in **Figure 5.2.2**. The Sunskirt is in place when the Sunskirt's angle hits the butt end of the rail (the Sunskirt will be covering about an inch of the rail). Tighten Nut to 12 ft-lbs. Repeat for all modules on the bottom edge of the array.

6. MAINTENANCE

- 6.1. Visually verify that no wires are in close proximity to the roof or sharp edges.
- 6.2. Visually inspect the solar panels for signs of damage to the glass or frame, or for signs of shifting.
- 6.3. Visually inspect all hardware connection points for loose or missing parts.
- 6.4. Mechanically check all torques against manufacturer's specifications.

7. NOTES

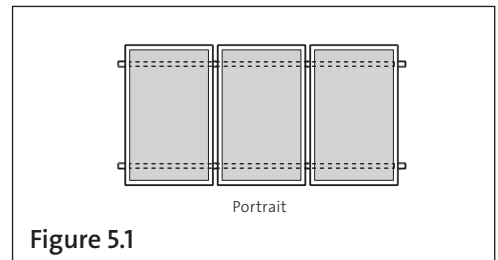

Figure 5.1

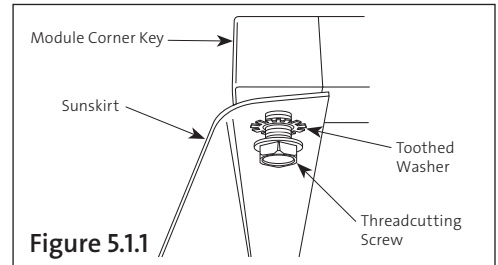

Figure 5.1.1

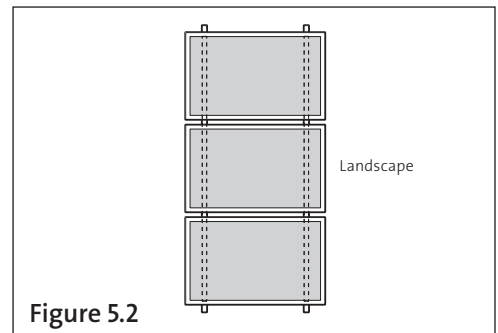

Figure 5.2

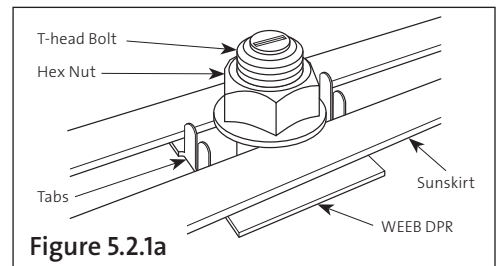

Figure 5.2.1a

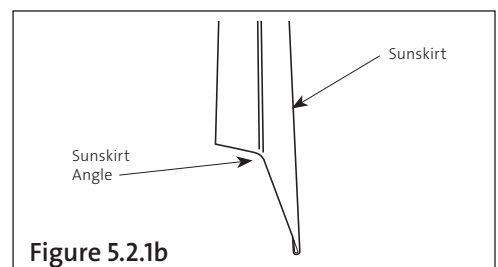

Figure 5.2.1b

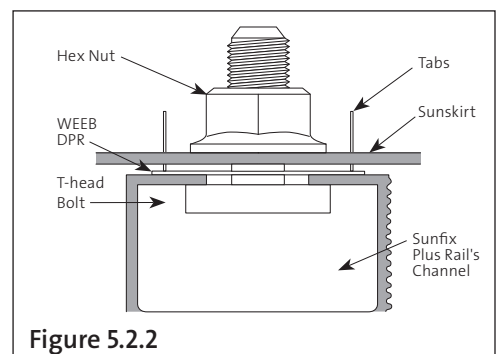

Figure 5.2.2